

General

General

1. Vibration Modes and Orientation Angles
 Regarding the vibration mode of the AT and BT cut, the orientation angle at which the primary coefficient of the frequency temperature characteristics near room temperature reaches zero is indicated in Fig.1

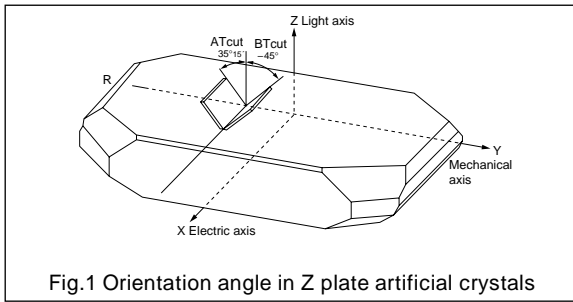

And the mode of thickness shear vibration is shown virtually in Fig.2

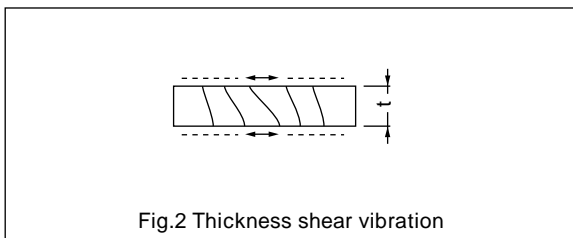

Regarding generally used AT and BT cut crystals, their frequency ranges and frequency coefficients (the relationship between the thickness of crystal plate and oscillation frequency) are shown in Fig.2

Table 1 Relationship between orientation angle and frequency.

Orientation angle	Frequency range (MHz)	Frequency (MHz)
AT (Fundamental)	3.5 ~ 30	$1.67 \times \frac{1}{t}$
AT (3rd. O.T.)	30 ~ 100	$5.01 \times \frac{1}{t}$
AT (5th. O.T.)	100 ~ 150	$8.35 \times \frac{1}{t}$
AT (7th. O.T.)	150 ~ 200	$11.69 \times \frac{1}{t}$
BT (Fundamental)	7 ~ 38	$2.56 \times \frac{1}{t}$

2. Frequency-temperature characteristics
 The frequency-temperature characteristics of a crystal are categorized into two types according to its shape of curve. One is a tertiary curve and the other is a quadratic curve. The typical frequency-temperature characteristics of AT and BT cuts are shown in Fig.3 and Fig.4, respectively. AT cut crystal units are most widely used because they produce smaller frequency changes in response to temperature changes in the room temperature range.

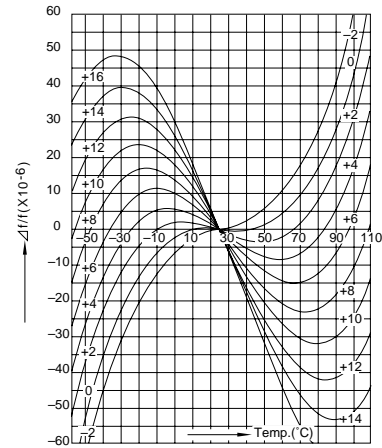

Fig.3 Example of AT cut frequency stability

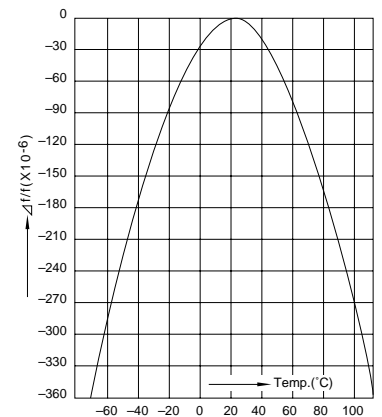

Fig.4 Example of BT cut frequency stability

3. Equivalent circuit and various constants
 The equivalent circuit of quartz crystal near the resonance frequency is represented by the arrangements shown in Fig.5.

- R₁: Series Resistance
- L₁: Motional Inductance
- C₁: Motional Capacitance
- C₀: Shunt Capacitance

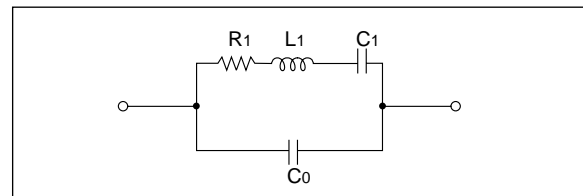

Fig.5 Equivalent circuit of quartz crystals

The admittance locus diagram of a crystal unit near its oscillation frequency and the equivalent circuit of a crystal unit are shown in Fig.6. This chart and figure show the configuration of the equivalent circuit under various circuit conditions and the relationship between oscillation frequency and resistance, etc. Here, we can find the following relationships among the various constants

- f_s (Series resonance frequency)
 $= 1 / (2 \sqrt{L_1 \cdot C_1})$
- f_p (Parallel resonance frequency)
 $= 1 / \{ 2 \sqrt{L_1 \cdot C_1 \cdot C_0 / (C_1 + C_0)} \}$
 $= f_s \{ 1 + 1 / (2\gamma) \}$
- γ (Capacitance ratio) = C_0 / C_1
- Q (Quality factor) = $2 \cdot f_s \cdot L_1 / R_1$
 $= 1 / (2 \cdot f_s \cdot C_1 \cdot R_1)$
- M (Figure of merit) = Q / γ
 $= 1 / (2 \cdot f_s \cdot C_0 \cdot R_1)$

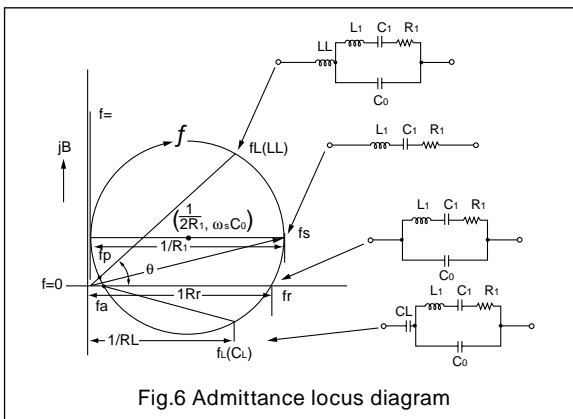

Fig.6 Admittance locus diagram

4 . Aging characteristics

The crystal's aging characteristics are determined by many factors, including the vibration mode used, the thickness of the crystal blanks, size, surface finish, electrode materials, mounting methods, sealing methods (hermeticity), cleanliness in the production process, heat treatment conditions, etc. The frequency aging characteristics are also influenced by the usage conditions of the quartz crystals. For example, it should be noted that high temperature activity might accelerate aging. Fig.11 demonstrates the frequency aging characteristics of typical quartz crystals.

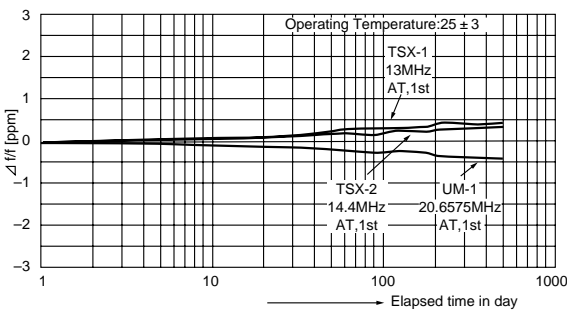

Fig.7 Frequency aging characteristics

Oscillation circuit with quartz crystal

When building an oscillation circuit with a quartz crystal unit, the following items should be considered.

1. Typical Oscillation Circuit (Fundamental oscillation mode)
 A typical oscillation circuit diagram is shown in Fig.8.

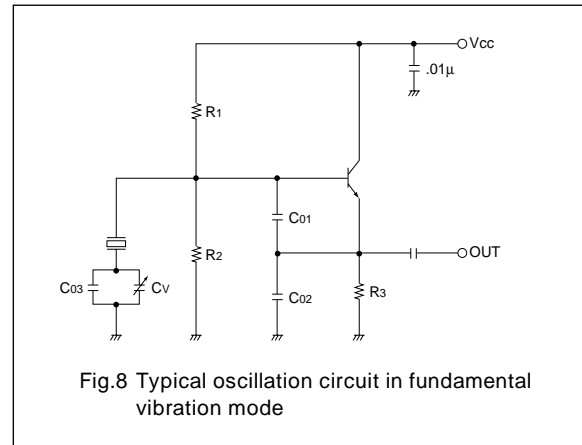

Fig.8 Typical oscillation circuit in fundamental vibration mode

When the oscillation mode is in a steady state, the relations among the reactance of crystal unit X_e , circuit reactance $-X$, impedance of crystal R_e and circuit impedance $-R$ are as follows:

$X_e = - X$

$R_e = | - R | \dots$

And the simplified oscillation circuit in a steady state is shown in Fig.9.

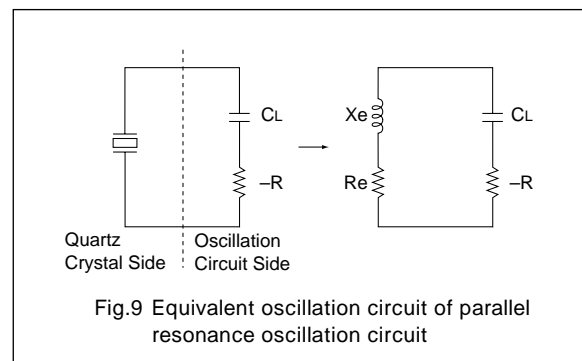

Fig.9 Equivalent oscillation circuit of parallel resonance oscillation circuit

To obtain secure oscillation of the circuit, the negative resistance of the circuit must satisfy the following equation $| - R | > R_e$.

Taking the circuit in Fig.8 as an example, the negative resistance of the circuit is shown as follows:

$- R = - gm / (\omega^2 \cdot C_{01} \cdot C_{02}) \dots$

Here,

gm = Mutual conductance of a transistor at the oscillation stage

$(= 2 \cdot f)$ = Oscillation angle frequency

2. Load capacitance and oscillation frequency

Given that

Series resonance frequency = f_r

Equivalent Series Capacitance = C_1

Parallel Capacitance = C_0
 Resonance Frequency (With Load Capacitance C_L) = f_L
 and $f_L - f_r = \Delta f$
 then,

$$\frac{\Delta f}{f_r} = \frac{f_L - f_r}{f_r} \approx \frac{1}{2(C_0/C_1)} \cdot \frac{1}{1 + C_L/C_0} = \frac{C_0}{2\gamma(C_0 + C_L)} \dots$$

The above equation is induced.
 The load capacitance can be regarded as the series capacitance of C_{01} , C_{02} and $C_{03} + C_V$, as shown in Fig.8., including stray capacitances of transistors and circuit patterns.
 Therefore, the load capacitance C_L is given by the following equation.

$$C_L = \left(\frac{1}{C_{01}} + \frac{1}{C_{02}} + \frac{1}{C_{03} + C_V} \right)^{-1} \dots$$

The "pulling range", the frequency variation range when the load capacitance of the oscillation circuit can be altered from C_{L1} to C_{L2} , is expressed as,

$$P.R. = \left| \frac{f_{L1} - f_{L2}}{f_r} \right| = \left| \frac{C_1(C_{L2} - C_{L1})}{2(C_0 + C_{L1})(C_0 + C_{L2})} \right| \dots$$

If the equivalent series capacitance C_1 , parallel capacitance C_0 , and the above C_{L1} and C_{L2} are given, the frequency variation range can be induced from the above equation. The "pulling Sensitivity", the sensitivity of an element near the load capacitance (C_L), is given by the following equation.

$$S = \frac{(\Delta f/f_r)}{C_L} \approx - \frac{C_1}{2(C_0 + C_L)^2} \dots$$

The resonance frequency vs. load capacitance characteristics are shown in Fig.10. The result of calculating the above equations under the given conditions of $C_1 = 16$ fF, $C_0 = 3.5$ pF, $C_L = 30$ pF, $C_{L1} = 27$ pF, and $C_{L2} = 33$ pF, is shown in Fig.10.

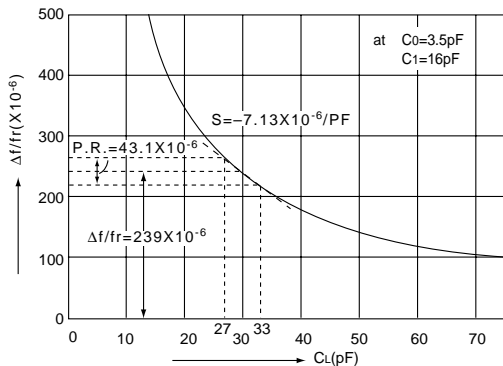

Fig.10 Frequency vs. load capacitance

By applying this phenomenon, the output frequency of the oscillation circuit can be trimmed to the nominal frequency, by adjusting a variable trimmer capacitor to offset the deviation due to production deviation of the crystal unit and the deviation of components in the oscillation circuit.

Although a reduction in the load capacitance (C_L) in Equation will increase the device sensitivity, it will also, conversely, decrease the stability. Please note that a reduction in the load capacitance will increase the difficulty in starting oscillation because the effective resistance of the crystal unit will increase, as shown in equation

$$R_L = R_1 \cdot (1 + C_0/C_L)^2 \dots$$

3. Overtone oscillation circuit

An example of an overtone oscillation circuit is shown in Fig.11. In comparison with a fundamental wave oscillation circuit (Fig.8.), there are two extra inductors in the circuit.

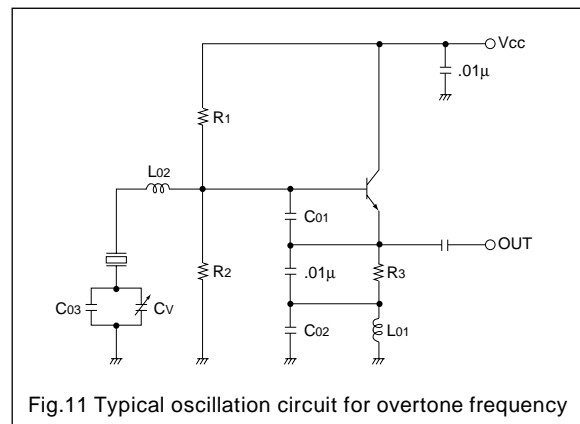

Fig.11 Typical oscillation circuit for overtone frequency

One of the added inductors (L_{01} : Connected to the emitter of a transistor (Q1)) comprises a frequency selection circuit along with C_{02} connected in parallel, suppressing fundamental or lower oscillation to stabilize overtone oscillation. This loop consisting of L_{01} and C_{02} is called a selection circuit. The condition in order to obtain selectivity is the configuration of the values of L_{01} and C_{02} so that the parallel resonance frequency of L_{01} and C_{02} ($f_r = 1/2\pi \sqrt{L_{01} \cdot C_{02}}$) is between the requested overtone frequency and the lower overtone frequency or fundamental frequency.

Next, the negative resistance of this circuit is to be explained further.

In equation , if you substitute $(C_{02} - 1 / \omega^2 L_{01})$ for C_{02} , the negative resistance $-R$ will be $-R = -gm / \{ \omega^2 \cdot C_{01} \cdot (C_{02} - 1 / \omega^2 \cdot L_{01}) \}$. The negative resistance will reduce in inverse proportion to the square of the frequency. Therefore, C_{01} and C_{02} must be of sufficiently small values in the case of overtone oscillation.

Another thing to be considered in the case of overtone oscillation is the frequency variable range. In equation , the value of the equivalent series capacitance is in inverse proportion to the square of the order of the overtone compared with that of the fundamental oscillation frequency, thus the range of frequency variation will be narrower. Both C_{01} and C_{02} will become small to ensure a negative resistance, making frequency tuning more difficult. However, this fact also shows that the frequency stability against turbulence outside the oscillation loop is heightened. To assure the frequency

variable range, an inductor L_{02} is often added. This inductor, L_{02} , is called an "extension inductor", and the load capacitance and the extension inductor is connected serially, as shown in Fig.12

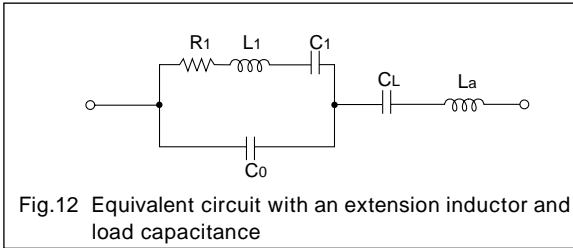

Fig.12 Equivalent circuit with an extension inductor and load capacitance

The variable frequency range at this condition is represented as

$$\frac{\Delta f}{f_r} \approx \frac{1}{2(C_0/C_1)} \cdot \frac{1}{1 + \frac{C_L}{C_0} \cdot \frac{1}{1 - \omega^2 L_a C_L}} \dots$$

In equation , if $L_a = 0$, then equation is induced. If you add an extension inductance in this case, please configure the values of C_L and L_a to satisfy the expression " $1 - 2L_a C_L = 0$ ".

Fig.13 shows a sample oscillation circuit diagram for a pager for your reference.

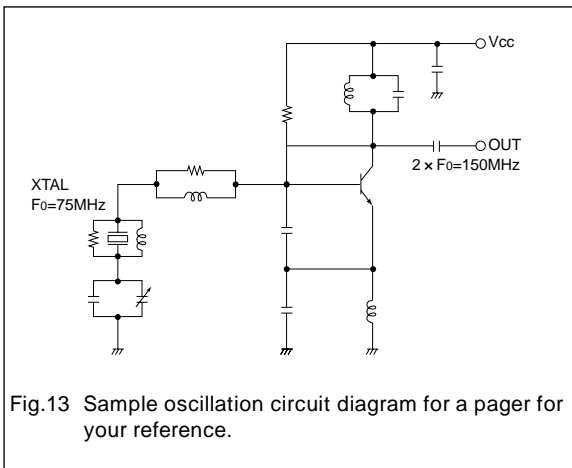

Fig.13 Sample oscillation circuit diagram for a pager for your reference.

4. Drive level of crystal oscillator

In order to ensure the stable oscillation of the crystal oscillator, a certain degree of drive power must be applied. Fig.14 shows how the frequency varies with the drive level, the amount of the frequency shift increasing as the drive level increases.

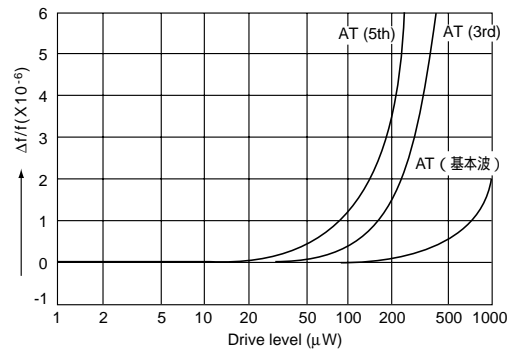

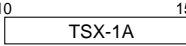

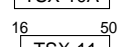
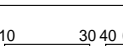
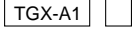

Fig.14 Frequency vs. drive level

Applying a high drive power (approx. 50mW) to a crystal unit will cause damage to it. For use in a normal oscillation circuit, the preferred drive power is 0.1 mW or less (max. 0.5 mW).

5. The following points must be considered when designing a PCB pattern.

- The pattern length from the oscillation stage to the crystal unit shall be the minimum in order to keep the stray capacitance of the oscillation loop to a minimum.
- When putting other components and wiring patterns over the oscillation loop, the increase of stray capacity shall be kept to a minimum.

CRYSTAL UNITS LINE UP

Holder type		Frequency range (MHz)		Applications
		1	10 100 500	
SMD type	TSX- Series	    	 	Reference oscillation for Bluetooth, Mobile communication equipment, Mobile phone, etc.
	TGX- Series	  	 	<ul style="list-style-type: none"> • Reference oscillation for Cordless phone • Clock oscillation for Digital still camera, Mobile communication equipment, etc.

FREQUENCY STABILITY (Frequency stability in operating temperature range referring at +25)

[Diagram TSX-Series, TGX-Series]

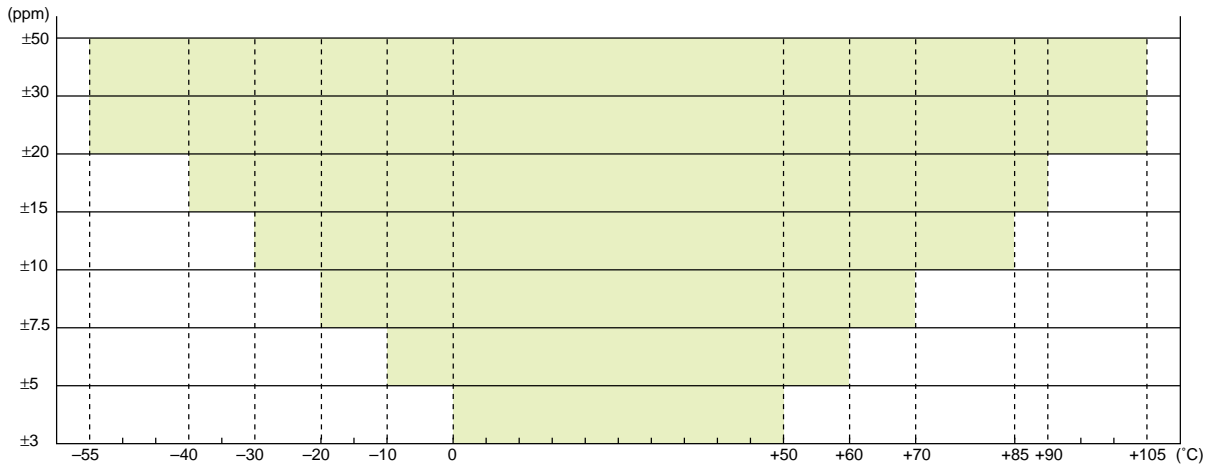

Colored specifications in above diagram are available.

Product Data

TSX - Series

Features

- Ultra miniaturised low profile
- Excellent shock-proof characteristics (10,000G min.)
- High reliable LCC package
- Available to surface mount technology and IR-reflow process
- Seam weld

Specifications

Holder	TSX-1A	TSX-5	TSX-8A	TSX-10A	TSX-11
Frequency range	10 ~ 150 MHz	12 ~ 30 MHz		12 ~ 50 MHz	16 ~ 50 MHz
Mode of vibration	Fundamental, 3rd, 5th	Fundamental			
Frequency tolerance	±10 ppm (at +25 °C ±2 °C)				
Load capacitance (CL)	Series, 20 pF, 30 pF, etc.				
Frequency stability	Refer to Diagram				
Resonance resistance (Rr)	Fundamental: 40 Ω Max 3rd: 50 Ω Max 5th: 80 Ω Max	40 Ω Max		12 ~ 16 MHz : 80Ω Max 16 ⁺ ~ 50 MHz : 40Ω Max	16 ~ 30 MHz : 80Ω Max 30 ⁺ ~ 50 MHz : 60Ω Max
Drive level	100 μW Max				
Aging	±1.0 ppm Max/year				

TGX - Series

Features

- Ultra miniaturised low profile
- Excellent shock-proof characteristics (10,000G min.)
- High reliable LCC package
- Available to surface mount technology and IR-reflow process
- Glass sealed

Specifications

Holder	TGX-A1	TGX-A5	TGX-8
Frequency range	10 ~ 30 MHz, 40 ~ 60 MHz	10.368 MHz, 12 ~ 30 MHz	12 ~ 30 MHz
Mode of vibration	Fundamental, 3rd	Fundamental	
Frequency tolerance	±10 ppm (at +25 °C ±2 °C)		±15 ppm (at +25 °C ±2 °C)
Load capacitance (CL)	Series, 20 pF, 30 pF, etc.		
Frequency stability	Refer to Diagram		
Resonance resistance (Rr)	Fundamental: 40 Ω Max 3rd: 80 Ω Max	40 Ω Max	80 Ω Max
Drive level	100 μW Max		
Aging	±1.0 ppm Max/year		±3.0 ppm Max/year

Outline Drawing (mm)

TSX - 1A

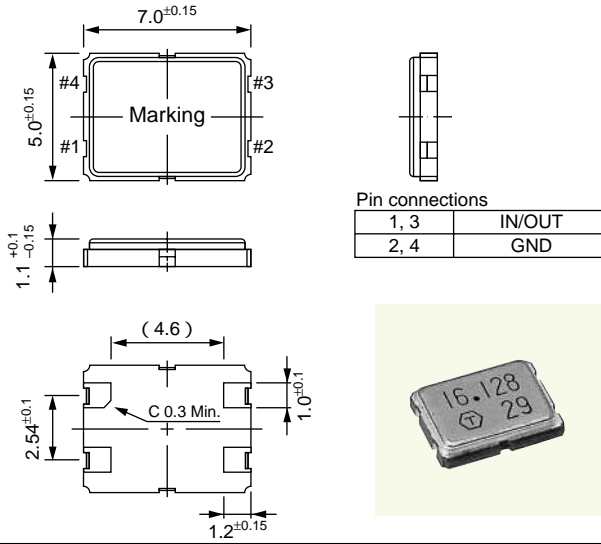

TSX - 5

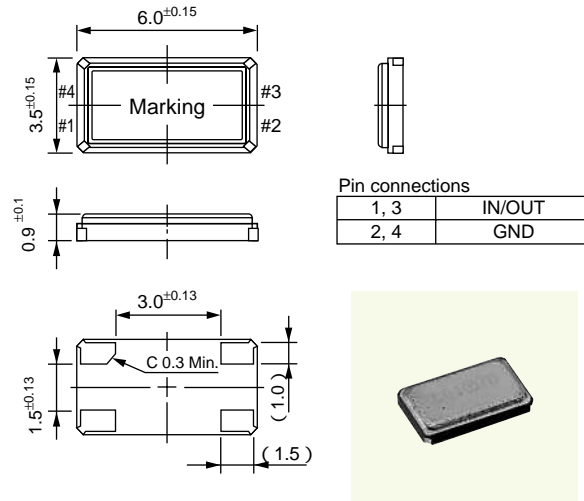

TSX - 8A

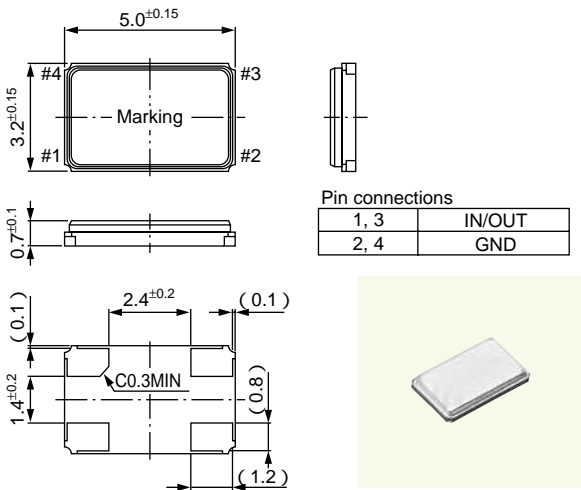

TSX - 10A

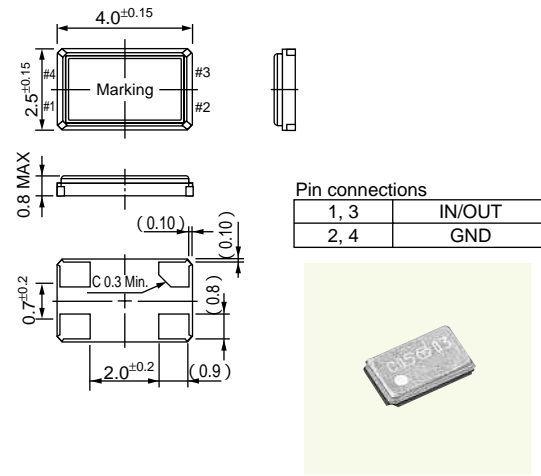

TSX - 11

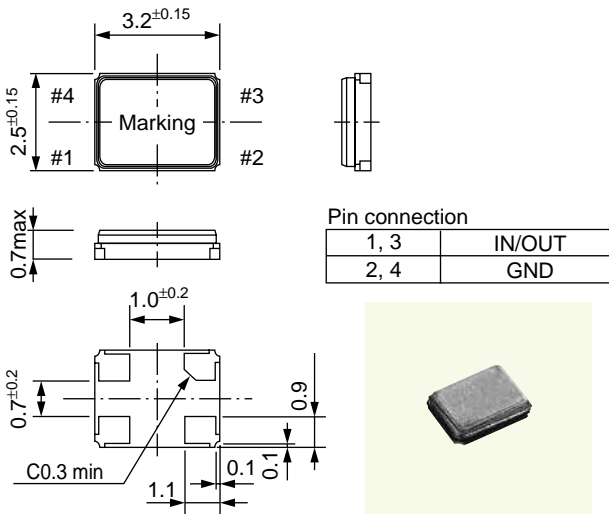

TGX - A1

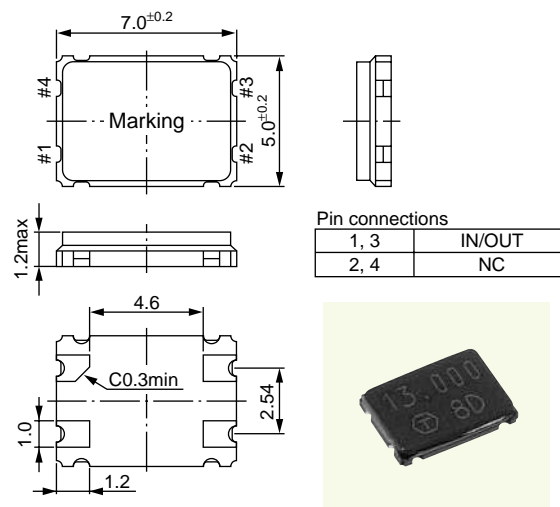

Outline Drawing (mm)

TGX - A5

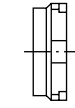
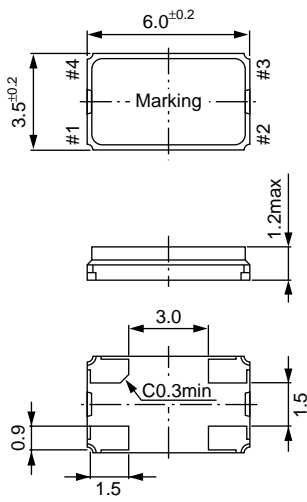

Pin connections

1, 3	IN/OUT
2, 4	NC



TGX - 8

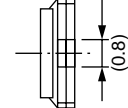
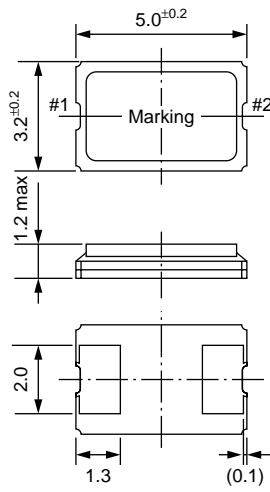

Pin connections

1, 2	IN/OUT
------	--------



Reference Footprint (mm)

TSX - 1A, TGX - A1

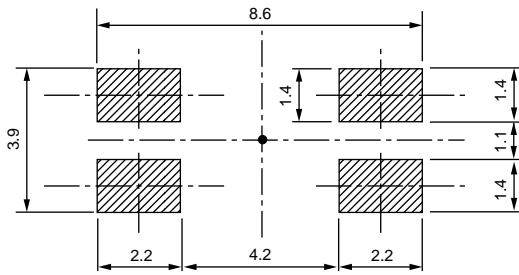

TSX - 5, TGX - A5

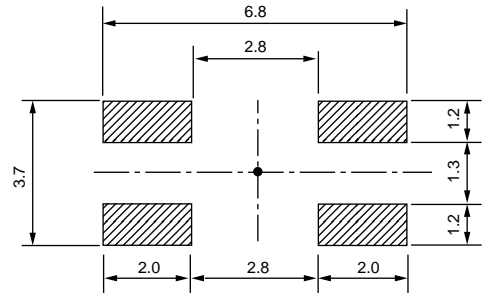

TSX - 8A

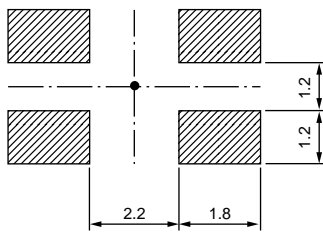

TGX - 8

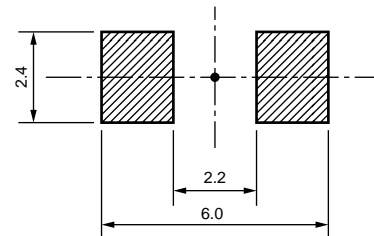

TSX - 10A

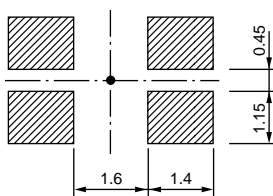

TSX - 11

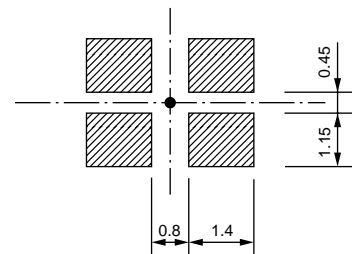

PACKAGING (Tape and Reel) [mm]

TSX - 1A, - 5, - 8A, - 10A, - 11, TGX - A1, - A5, - 8

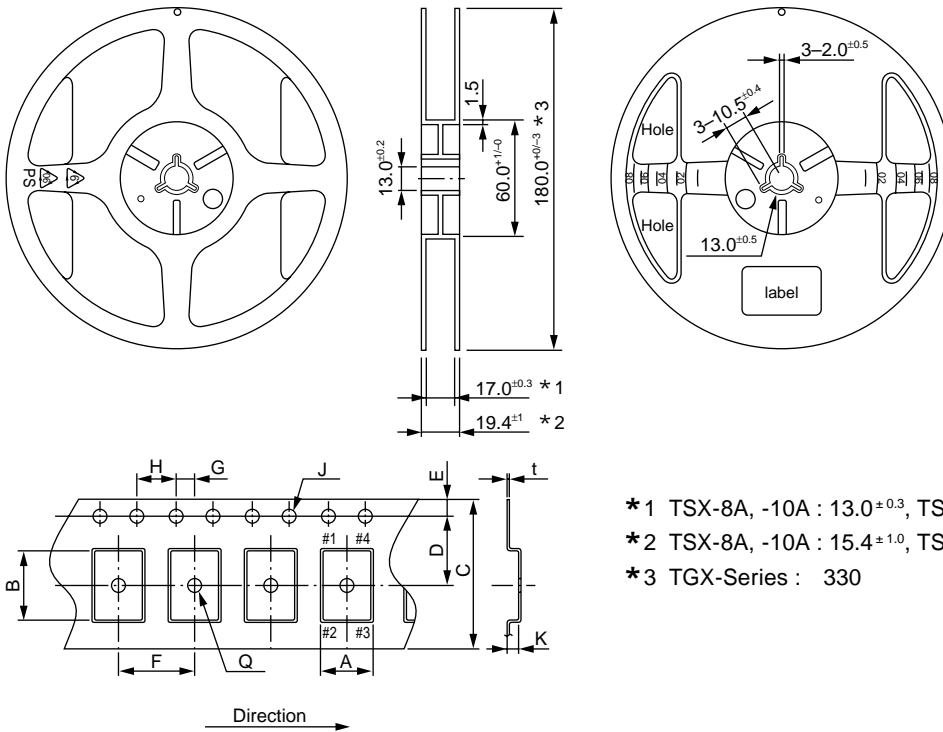

- *1 TSX-8A, -10A : 13.0±0.3, TSX-11 : 9.0±0.3
- *2 TSX-8A, -10A : 15.4±1.0, TSX-11 : 11.4±1.0
- *3 TGX-Series : 330

- Standard quantity of TSX-10A : 2,000 pcs/reel
- Standard quantity of TGX-Series : 4,000 pcs/reel
- Standard quantity of others : 1,000 pcs/reel
- Carrier tape : Antistatic material (PS)
- Each reel can be recycled

	TSX-1A TGX-A1	TSX-5 TGX-A5	TSX-8A	TGX-8	TSX-10A	TSX-11
A	5.4±0.1	3.9±0.1	3.5±0.1	3.5±0.1	2.9±0.1	2.9±0.1
B	7.4±0.1	6.4±0.1	5.4±0.1	5.4±0.1	4.4±0.1	3.6±0.1
C	16.0±0.2	16.0±0.2	12.0±0.2	12.0±0.2	12.0±0.2	8.0±0.2
D	7.5±0.1	7.5±0.1	5.5±0.1	5.5±0.1	5.5±0.1	3.5±0.1
E	1.75±0.1	1.75±0.1	1.75±0.1	1.75±0.1	1.75±0.1	1.75±0.1
F	8.0±0.1	8.0±0.1	8.0±0.1	8.0±0.1	4.0±0.1	4.0±0.1
G	2.0±0.1	2.0±0.1	2.0±0.1	2.0±0.1	2.0±0.1	2.0±0.1
H	4.0±0.1	4.0±0.1	4.0±0.1	4.0±0.1	4.0±0.1	4.0±0.1
J	1.55±0.05	1.55±0.05	1.5 ^{+0.1/0}	1.5 ^{+0.1/0}	1.5 ^{+0.1/0}	1.5 ^{+0.1/0}
K	1.4±0.1	1.5±0.1	1.0±0.1	1.5±0.1	0.9±0.1	1.0±0.1
Q	1.6 ^{+0.1/0}	1.55±0.05	1.6±0.1	1.6±0.1	1.5 ^{+0.1/0}	1.0 ^{+0.2/0}
t	0.3±0.05	0.3±0.05	0.25±0.05	0.25±0.05	0.25±0.05	0.25±0.05

Inquiry and Ordering Information

Application	_____
Part Number	_____
Nominal Frequency	_____ Hz
Vibration Mode	_____
Frequency Tolerance (at +25 ±2)	_____ ppm
Load Capacitance (CL)	_____ pF
Frequency Stability in Operating Temperature Range(Referred to +25)	_____ ppm
	_____ ~ _____
Resonance Resistance (Rr)	_____ Ω Max.
Motional Capacitance (C1)	_____ fF
Shunt Capacitance (C0)	_____ pF
Drive level	_____ mW
Other Requirements, if any	_____
(Option, Marking, etc.)	_____